



**CONSENT AGENDA  
DRAINAGE DISTRICT  
BOARD OF DIRECTORS  
November 22, 2016  
9:00 A.M.**

**NOTICE is hereby given in accordance with Chapter 551, Texas Government Code, that a REGULAR MEETING of the Drainage District #1 Board of Directors will be held in the Commissioners' Courtroom of the Administration Building, 100 E. Cano, 1st floor, Edinburg, Hidalgo County, Texas. Discussion and possible action relating to the following business will be transacted:**

**NOTICE TO THE PUBLIC  
CONSENT AGENDA**

**The following items are of a routine or administrative nature. The Drainage District #1 Board has been furnished with background and support on each item, and/or it has been discussed at a previous meeting. All items will be acted upon by one vote without being discussed separately unless requested by a Board Member, in which event the item or items will immediately be withdrawn for individual consideration in its normal sequence after the items not requiring separate discussion have been acted upon. The remaining items will be adopted by one vote.**

1. Approval of check register and payment of claims and bills - County Treasurer
  
2. **AI -57431** Discharge Permit  
Quintanilla, Headley & Associates, Inc.- San Agustin Subdivision Phase I (Discharge A)
  
3. **AI -57432** Discharge Permit-  
Quintanilla, Headley & Associates, Inc.- San Agustin Subdivision Phase I (Discharge B)
  
4. **AI -57392** Discharge Permit  
MAS Engineering- Las Palmas Industrial Park Subdivision
  
5. **AI -57438 General Fund  
Budget 010-Raymondville Drain**  
A. Invoice No. U9444.103/812-17B in the amount of \$92,226.00 from S&B Infrastructure related to Work Authorization No. 17-TWDB Service for Phase II MDS System.  
PO#626525

**2013 Bonds**  
**Budget 365-Rural Drainage Development Pct.1**

B. Invoice no. 1116112806 in the amount of \$4,054.44 from Urban Infrastructure Group, Inc. pertaining to Work Authorization No. 6-Engineering Services for Los Olivarez Acres Drain to Ditch 4E2A. PO#630494.

C. Invoice No. 1116112800 in the amount of \$4,795.16 from Urban Infrastructure Group, Inc. pertaining to Work Authorization No. 1-Engineering Services for Los Olivarez Acres Drain to Ditch 4E2A. PO#628833.

**6. AI -57455** General Fund  
Budget 006-M&O

Invoice No. M217472 in the amount of \$82,904.86 from Halff & Associates, Inc. Pertaining to WA#2-Engineering Services for Firing Range. PO#629455

**AI -57431**

**2.**

**DRAINAGE - CONSENT**

Meeting Date: 11/22/2016

Submitted For: Esther Layton

Submitted By: Esther Layton, DRAINAGE  
DISTRICT

Department: DRAINAGE DISTRICT

---

Information

CAPTION

Discharge Permit

Quintanilla, Headley & Associates, Inc.- San Agustin Subdivision Phase I  
(Discharge A)

BACKGROUND

---

Fiscal Impact

Attachments

Discharge Permit

---

**Form Review**

**Inbox**

**Reviewed By**

**Date**

Final Approval

Monica Badillo

11/18/2016 05:28 PM

Form Started By: Esther Layton

Started On: 11/17/2016 04:42 PM

Final Approval Date: 11/18/2016

APPLICATION FOR DISCHARGING STORM WATER  
INTO H.C.D.D. NO. 1 SYSTEM\*\*

Applicant: City of Alamo Permit No: \_\_\_\_\_

Address: 420 N. Tower Road, Alamo Road 78516

Subdivision Name: San Agustin Subdivision Phase I (Discharge A)

Name of Receiving Ditch: H.C.D.D. No.1 Alamo Expressway Drain

Location or Drainage Area (Furnish Location Map): see attached layout

X(coordinate): 98°06'10" W Y(coordinate): 26°10'16" N  
(NAD 1983 Texas South FIPS 4205 feet)

New or existing entrance: New Calculated Run-off: 47.56 c.f.s.

Number of Acres Developed: 60.17 ac Size of Pipe: 48" R.C.P.

Size of Box Culvert: N/A Ditch Lateral (size of entrance) sq. ft.: N/A

Discharge Flow line of Pipe, Box Culvert, Ditch Lateral: 82.84

Flow line Receiving Ditch: 81.84 Top of Water Receiving Ditch: 82.84

Top of Ditch Elevation: 96.60 Top of water of Connecting Ditch Lateral: N/A

Head Loss Calculated: 1.42 Formula Used: TxDOT Nomograph

Project Engineer: Alfonso Quintanilla, P.E. Quintanilla, Headley & Associates, Inc  
(Engineer's Name) (Firm's Name)

124 E. Stubbs St. Edinburg, Texas 78539 (956) 381-6480 (956) 381-0527  
(Address) (Phone #) (Fax #)

\*Owner shall be considered a City with the appropriate review boards considering/granting approval to subdivision; otherwise owner/developer signature will be required.

\_\_\_\_\_  
(Owner's Signature)

*Alfonso Quintanilla*  
(Mayor's Signature) (City of)

\_\_\_\_\_  
(Mayor-Print Name) (Date)

APPROVAL OF IRRIGATION DISTRICT

This is to certify that we have reviewed the above application and we hereby approve the plan and application as shown.

\_\_\_\_\_  
(Irrigation District)

By: \_\_\_\_\_

Title: \_\_\_\_\_

Date: \_\_\_\_\_

If not an Irrigation District facility, please sign on line below as acknowledgement:

HCDD #2 *Sonny Livingston* 10/24/16  
(Irrigation District)

APPROVAL OF DRAINAGE DISTRICT

APPROVED this \_\_\_\_\_ day of \_\_\_\_\_, 20 \_\_\_\_.

By: \_\_\_\_\_  
(Hidalgo County Drainage District Number One)

\*\* This application requires Board of Director's approval. Please submit application, to the District, on Tuesday's before 5:00 p.m. to be placed on Board of Director's meeting the following Tuesday.

**AI -57432**

**3.**

**DRAINAGE - CONSENT**

Meeting Date: 11/22/2016

Submitted For: Esther Layton

Submitted By: Esther Layton, DRAINAGE  
DISTRICT

Department: DRAINAGE DISTRICT

---

Information

CAPTION

Discharge Permit-  
Quintanilla, Headley & Associates, Inc.- San Agustin Subdivision Phase I  
(Discharge B)

BACKGROUND

---

Fiscal Impact

Attachments

Discharge Permit

---

**Form Review**

<b>Inbox</b>	<b>Reviewed By</b>	<b>Date</b>
Final Approval	Monica Badillo	11/18/2016 05:28 PM
Form Started By: Esther Layton		Started On: 11/17/2016 04:53 PM
Final Approval Date: 11/18/2016		

APPLICATION FOR DISCHARGING STORM WATER  
INTO H.C.D.D. NO. 1 SYSTEM\*\*

Applicant: City of Alamo Permit No: \_\_\_\_\_

Address: 420 N. Tower Road, Alamo Road 78516

Subdivision Name: San Agustin Subdivision Phase I (Discharge B)

Name of Receiving Ditch: H.C.D.D. No.1 Alamo Expressway Drain

Location or Drainage Area (Furnish Location Map): see attached layout

X(coordinate): 98°06'10" W Y(coordinate): 26°10'16" N  
(NAD 1983 Texas South FIPS 4205 feet)

New or existing entrance: New Calculated Run-off: 47.56 c.f.s.

Number of Acres Developed: 60.17 ac Size of Pipe: 18" R.C.P.

Size of Box Culvert: N/A Ditch Lateral (size of entrance) sq. ft.: N/A

Discharge Flow line of Pipe, Box Culvert, Ditch Lateral: 85.50

Flow line Receiving Ditch: 82.67 Top of Water Receiving Ditch: 83.67

Top of Ditch Elevation: 95.50 Top of water of Connecting Ditch Lateral: N/A

Head Loss Calculated: 2.62 Formula Used: TxDOT Nomograph

Project Engineer: Alfonso Quintanilla, P.E. Quintanilla, Headley & Associates, Inc  
(Engineer's Name) (Firm's Name)

124 E. Stubbs St. Edinburg, Texas 78539 (956) 381-6480 (956) 381-0527  
(Address) (Phone #) (Fax #)

\*Owner shall be considered a City with the appropriate review boards considering/granting approval to subdivision; otherwise owner/developer signature will be required.

\_\_\_\_\_  
(Owner's Signature) *Deana Martinez* (Mayor's Signature) \_\_\_\_\_ (City of)  
\_\_\_\_\_  
(Mayor-Print Name) \_\_\_\_\_ (Date)

APPROVAL OF IRRIGATION DISTRICT

This is to certify that we have reviewed the above application and we hereby approve the plan and application as shown.

\_\_\_\_\_  
(Irrigation District)

By: \_\_\_\_\_

Title: \_\_\_\_\_

Date: \_\_\_\_\_

If not an Irrigation District facility, please sign on line below as acknowledgement:

HIDALGO COUNTY IRRIGATION DISTRICT NO. 2. *Sammy Henriquez*  
(Irrigation District)

APPROVAL OF DRAINAGE DISTRICT

APPROVED this \_\_\_\_\_ day of \_\_\_\_\_, 20 \_\_\_\_\_.

By: \_\_\_\_\_  
(Hidalgo County Drainage District Number One)

\*\* This application requires Board of Director's approval. Please submit application, to the District, on Tuesday's before 5:00 p.m. to be placed on Board of Director's meeting the following Tuesday.

**AI -57392**

**4.**

**DRAINAGE - CONSENT**

Meeting Date: 11/22/2016

Submitted For: Esther Layton

Submitted By: Esther Layton, DRAINAGE  
DISTRICT

Department: DRAINAGE DISTRICT

---

Information

CAPTION

Discharge Permit

MAS Engineering- Las Palmas Industrial Park Subdivision

BACKGROUND

---

Fiscal Impact

Attachments

Discharge Permit

---

**Form Review**

<b>Inbox</b>	<b>Reviewed By</b>	<b>Date</b>
Final Approval	Monica Badillo	11/18/2016 05:28 PM
Form Started By: Esther Layton		Started On: 11/16/2016 10:14 AM
Final Approval Date: 11/18/2016		

APPLICATION FOR DISCHARGING STORM WATER INTO HCDD1 SYSTEM AND/OR HCID SYSTEM

Applicant: RTE Investments, LLC Permit No: \_\_\_\_\_

Address: Po Box 4230 McAllen, TX 78502-4230

Subdivision Name: Las Palmas Industrial Park

Name of Receiving Ditch: Hidalgo Drain

Location or Drainage Area (Furnish Location Map): see attached location map

X (coordinate): 26.132636 Y (coordinate): -98.232922

(NAD 1983 Texas South FIPS 4205 feet)  
New or existing entrance: New Calculated Discharge (Q): 7.2 cfs

Number of Acres Developed: 50.40 Size of Discharge Structure: 18"

Discharge Flow line of Discharge Structure: 84.50

Flow line Receiving Ditch: 83.50 Top of Water Receiving Ditch: 83.60

Top of Receiving Ditch Elevation: 93.32 Top of water of Connecting Ditch Lateral: \_\_\_\_\_

Head Loss Calculated: 1.6 Formula Used: TX DOT HYDRAULIC

Project Engineer: MARIO A. SALINAS MAS ENGINEERING, LLC  
(Engineer's Name) (Firm's Name)

3911 N. 10th Street, suite H McAllen, TX 78501 (956) 537-1311  
(Address) (Phone #) (Fax #)

M. A. Salinas 11/14/16  
(Engineer Signature) (Date)

\*Owner shall be considered a City with the appropriate review boards considering/granting approval to subdivision; otherwise owner/developer signature will be required.

\_\_\_\_\_  
(Mayor's Signature) (City of) \_\_\_\_\_  
(Owner's Signature) Date 11-14-16

\_\_\_\_\_  
(Mayor-Print Name) (Date)

APPROVAL OF IRRIGATION DISTRICT

This is to certify that we have reviewed the above application and we hereby approve the plan and application as shown. If not an Irrigation District facility, please fill out info and initial next to statement:

Irrigation District  
By (Printed Name): \_\_\_\_\_ Signature: \_\_\_\_\_  
Title: \_\_\_\_\_ Date: \_\_\_\_\_

Not an Irrigation District Facility \_\_\_\_\_

APPROVAL OF DRAINAGE DISTRICT

APPROVED this \_\_\_\_\_ day of \_\_\_\_\_, 20 \_\_\_\_.

By: \_\_\_\_\_  
(Chairman of the Board HCDD1)

\*\* This application requires Board of Director's approval. Irrigation District approval, if required, will be needed before HCDD1 may consider formal action on application. Please submit application, to the District, on Tuesday's before 5:00 p.m. to be placed on Board of Director's meeting the following Tuesday.

**AI -57438**

**5.**

**DRAINAGE - CONSENT**

Meeting Date: 11/22/2016

Submitted By: Claudette Guerrero,  
DRAINAGE DISTRICT

Department: DRAINAGE DISTRICT

---

Information

CAPTION

**General Fund**

**Budget 010-Raymondville Drain**

A. Invoice No. U9444.103/812-17B in the amount of \$92,226.00 from S&B Infrastructure related to Work Authorization No. 17-TWDB Service for Phase II MDS System.  
PO#626525

**2013 Bonds**

**Budget 365-Rural Drainage Development Pct.1**

B. Invoice no. 1116112806 in the amount of \$4,054.44 from Urban Infrastructure Group, Inc. pertaining to Work Authorization No. 6-Engineering Services for Los Olivarez Acres Drain to Ditch 4E2A.  
PO#630494.

C. Invoice No. 1116112800 in the amount of \$4,795.16 from Urban Infrastructure Group, Inc. pertaining to Work Authorization No. 1-Engineering Services for Los Olivarez Acres Drain to Ditch 4E2A.  
PO#628833.

BACKGROUND

---

Fiscal Impact

Attachments

S&B Inv#U9444.103/812-17B

Urban Inv#112800

Urban Inv#112806

---

**Form Review**

**Inbox**

Final Approval

Form Started By: Claudette Guerrero

Final Approval Date: 11/18/2016

**Reviewed By**

Monica Badillo

**Date**

11/18/2016 05:28 PM

Started On: 11/18/2016 09:19 AM



# Hidalgo County Drainage District No. 1

902 North Doolittle Road, Edinburg, TX 78542 Office: 956-292-7080

## Invoice Processing Routing Slip

Invoice/ Backup

Date Received: 11/2/2016

Engineer/Firm Name: S&B Infrastructure

Project Name/Number: Raymondville Drain Project, WA No. 17

Invoice No.: U9444.103&812-17B

Invoice Date: 7/25/2016

Due Date: 12/2/2016

Purchase Order No.: 626525

Amount: \$92,226.00

Total # of Pages Submitted: 4

Attachments:  CD  USB  Plans Other: \_\_\_\_\_

Engineering:

Construction:

Received By: Maria Perez

### Forwarded to:

Nora D. Cavazos \_\_\_\_\_ Date: \_\_\_\_\_

Esther Layton \_\_\_\_\_ Date: \_\_\_\_\_

Claudette Guerrero \_\_\_\_\_ Date: \_\_\_\_\_

Jose N. Saldivar \_\_\_\_\_ Date: \_\_\_\_\_

Lora Briones \_\_\_\_\_ Date: \_\_\_\_\_

Additional Comments: \_\_\_\_\_  
\_\_\_\_\_  
\_\_\_\_\_



**Raymondville Drain Project, Project for Flood Control**  
*Lower Rio Grande Basin, (Hidalgo & Willacy Counties), Texas*  
Water Resources Development Act (WRDA) 1986, Title IV, Section 401,  
As Amended by WRDA 2007



## INVOICE TRANSMITTAL

S&BI Invoice U9444.103&812-17B

21 October 2016

RECEIVED  
HIDALGO COUNTY  
DRAINAGE DISTRICT #1

NOV 02 2016

8:36 AM/PM

BY:

To: Lora Briones, HCDD1 Financial Officer  
Claudette Guerrero, HCDD1 Accountant  
José "Noe" Saldivar, PE, HCDD1 Engineer

From: Sharlotte L. Teague, PE, S&BI Senior Project Manager

Dear Lora, Claudette, and Noe,

Transmitted herewith is above-referenced S&BI invoice. Under this invoice, we are respectfully requesting payment as follows:

**Work Performed Under:** S&BI Work Authorization No. 17

**Performance Period:** thru June 30, 2016

**Work Tasks Performed:**

For this invoice, we are primarily requesting compensation for **the following** work (see "Expanded Progress Report" attached to invoice; tasks performed are outlined as follows:

**1. GCM :**

- a. Created Project Description of RESTORE Act Project for agency coordination
- b. Identified components needed for the FEMA Hazard Mitigation Action Plan
- c. Began developing applications for FEMA 4245 DR
- d. Identified potential conflicting FAA Regulations with in-line and off-line detention areas
- e. Meetings included:
  - 2016-6-09 Internal Team Meeting – Phase 1 Interim Build Options

**2. H&H Design (WC):**

- a. Updated BCR to reflect various changes in design and WSE
- b. Created an HMS model to compare runoff inflows vs pump outflows at different rainfall frequencies for an Interim Build of Phase 1 Segment 1.
- c. Updated Flood Mitigation Models where Delta Lake South Main Drain connects to the RVD
- d. Updated inline storage capacities through various reaches
- e. Adjusted HMS Models to 24-hour flows for Willacy Reaches
  - HMS Models
  - SAR from HMS Outputs
- f. Updated HEC-RAS Models to Reflect Various Adjustments
- g. Prepared Water Elevation Reports

**3. Engineering – Final Schematic (WC):**

- a. Updated project schematic to reflect work performed

Electronic back-up has been provided in the attached USB.



**Raymondville Drain Project, Project for Flood Control**  
*Lower Rio Grande Basin, (Hidalgo & Willacy Counties), Texas*

Invoice Transmittal, S&BI Invoice U9444.103&812-17b, 21 October 2016

A handwritten signature in blue ink, appearing to be "S. Lynne Teague", is written over a horizontal line.

Respectfully Submitted By: \_\_\_\_\_

Charlotte Lynne Teague, PE

Attachments: S&BI Invoice U9444.103&812-17a with Expanded Line-Item Progress Report  
USB (Electronic Copies of Technical Back-up as listed above and Sub-provider Invoice)





RECEIVED  
HIDALGO COUNTY  
DRAINAGE DISTRICT #1

NOV 02 2016

8:36 AM/PM

BY: MAP

**INVOICE**

July 25, 2016

Hidalgo County Drainage District No. 1  
Attention: Lora Briones, Financial Officer  
902 N. Doolittle  
Edinburg, Texas 78542

Project Description:  
Raymondville Drain  
Work Authorization No. 17 "Hidalgo and Willacy Counties - Planning, Design, Preliminary Engineering"

S&B Invoice No.: U9444.103/812-17B  
Invoice Period: June 1, 2016 through June 30, 2016

	QTY	UNIT	UNIT PRICE	PERCENT COMPLETE	INVOICED TO DATE	PREVIOUSLY INVOICED	AMOUNT THIS INVOICE
Hidalgo & Willacy Counties -Planning, Design, Preliminary Engineering, and PS&E	1	LS	\$5,599,008	64%	\$ 3,598,503.00	\$ 3,506,276.00	\$ 92,226.00
<b>PAYMENT IS REQUESTED IN THE AMOUNT OF:</b>							<b>\$ 92,226.00</b>

I hereby certify that this invoice is true and correct, and that all services indicated have been provided.

S & B INFRASTRUCTURE, LTD.



Charlotte L. Teague, PE  
Senior Project Manager

IN ACCORDANCE WITH OUR CONTRACT,  
PLEASE REMIT **BY FED EX:** \$ 92,226.00

**FED EX ACCOUNT NO. 2887-7404-8**

S&B INFRASTRUCTURE, LTD.  
ATTN: MIKE MANTHOS PHONE: 713.845.5401  
3535 Sage Road  
Houston, Texas 77056

Attachments:  
PROGRESS REPORT NO. 17B



**Raymondville Drain, Project for Flood Control**  
**Hidalgo County Drainage District No. 1 / S&B Infrastructure, Ltd.**  
**Work Authorization No. 17**

<b>Expanded Progress Report</b>					
<b>U9444.103&amp;812-17A</b>					
<b>Thru June 30, 2016</b>					
<b>Expanded Description</b>	<b>Estimated Line Item Budget</b>	<b>% Complete</b>	<b>Invoice To-Date Amount</b>	<b>Previously Invoiced</b>	<b>Amount Due This Invoice</b>
<b>Work Authorization No. 17:</b>					
1 GCM	\$703,663	85%	\$ 595,250	\$ 580,522	\$ 14,728
2 Engineering / Design (HC)	\$653,667	85%	\$ 555,617	\$ 555,617	-
3 Prelim Compensable Utilities (HC)	\$227,008	65%	\$ 147,555	\$ 147,555	-
4 H&H Design (WC)	\$930,776	80%	\$ 744,621	\$ 718,219	\$ 26,402
5 Engineering - Final Schematic (WC)	\$893,524	46%	\$ 408,506	\$ 357,410	\$ 51,096
6 Prelim ROW / Design Survey (WC)	\$354,932	25%	\$ 88,733	\$ 88,733	-
7 Prelim ROW Acquis Admin (WC)	\$270,500	0%	-	-	-
8 Geotechnical (WC)	\$1,564,938	68%	\$ 1,058,217	\$ 1,058,217	-
<b>SUB-TOTAL (WA 17):</b>	<b>\$5,599,008</b>	<b>64%</b>	<b>\$ 3,598,500</b>	<b>\$ 3,506,275</b>	<b>\$ 92,226</b>

Invoice Backup  
U9444.103 4812 ~ 116





# Hidalgo County Drainage District No. 1

902 North Doolittle Road, Edinburg, TX 78542 Office: 956-292-7080

## Invoice Processing Routing Slip

Invoice/ Backup

Date Received: 11/7/2016

Engineer/Firm Name: Urban Infrastructure Group, Inc.

Project Name/Number: Pct.1 Mile 13.5 and 1015 Area DIP, WA No. 1

Invoice No.: 1116112800

Invoice Date: 11/4/2016

Due Date: 12/7/2016

Purchase Order No.: 628833

Amount: \$4,795.16

Total # of Pages Submitted: 10

Attachments:  CD  USB  Plans Other: \_\_\_\_\_

Engineering:

Construction:

Received By: Maria Perez

### Forwarded to:

Nora D. Cavazos \_\_\_\_\_ Date: \_\_\_\_\_

Esther Layton \_\_\_\_\_ Date: \_\_\_\_\_

Claudette Guerrero \_\_\_\_\_ Date: \_\_\_\_\_

Jose N. Saldivar \_\_\_\_\_ Date: \_\_\_\_\_

Lora Briones \_\_\_\_\_ Date: \_\_\_\_\_

Additional Comments: \_\_\_\_\_  
\_\_\_\_\_  
\_\_\_\_\_



**URBAN  
INFRASTRUCTURE  
GROUP, INC.**

November 4, 2016

**RECEIVED**  
HIDALGO COUNTY  
DRAINAGE DISTRICT #1

Jaime Salazar, Operations Manager  
Hidalgo County Drainage District No.1  
902 N. Doolittle  
Edinburg, Texas 78542

NOV 07 2016

4:30 AM/PM

BY: MAP

RE: Invoice No. 1116112800

Project Name:	Pct. 1 – Mile 13 ½ and 1015 area Drainage Improvement Project
Project Number:	112800

Invoice Period:	July - October 2016
-----------------	---------------------

This invoice is for engineering services pertaining to the Los Olivarez Acres Drain to Ditch 4E2A project. Attached with this invoice is our Monthly Progress Report. Below shows the amount billed for each Work Authorization (WA). If you have any questions please don't hesitate to call me.

	Complete This Month	Contract Amount	Amount This Month	Total
<b>Professional Services</b>				
WA#1 PO 628833 (85% Complete)	10%	\$47,951.57	\$4,795.16	\$4,795.16

<b>TOTAL AMOUNT DUE:</b>	<b>\$4,795.16</b>
--------------------------	-------------------

*I certify that the above information is true and correct.*

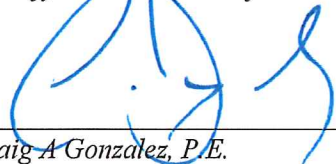
  
\_\_\_\_\_  
Craig A Gonzalez, P.E.  
Principal

*We appreciate the opportunity to serve you on this project.  
God Bless.*

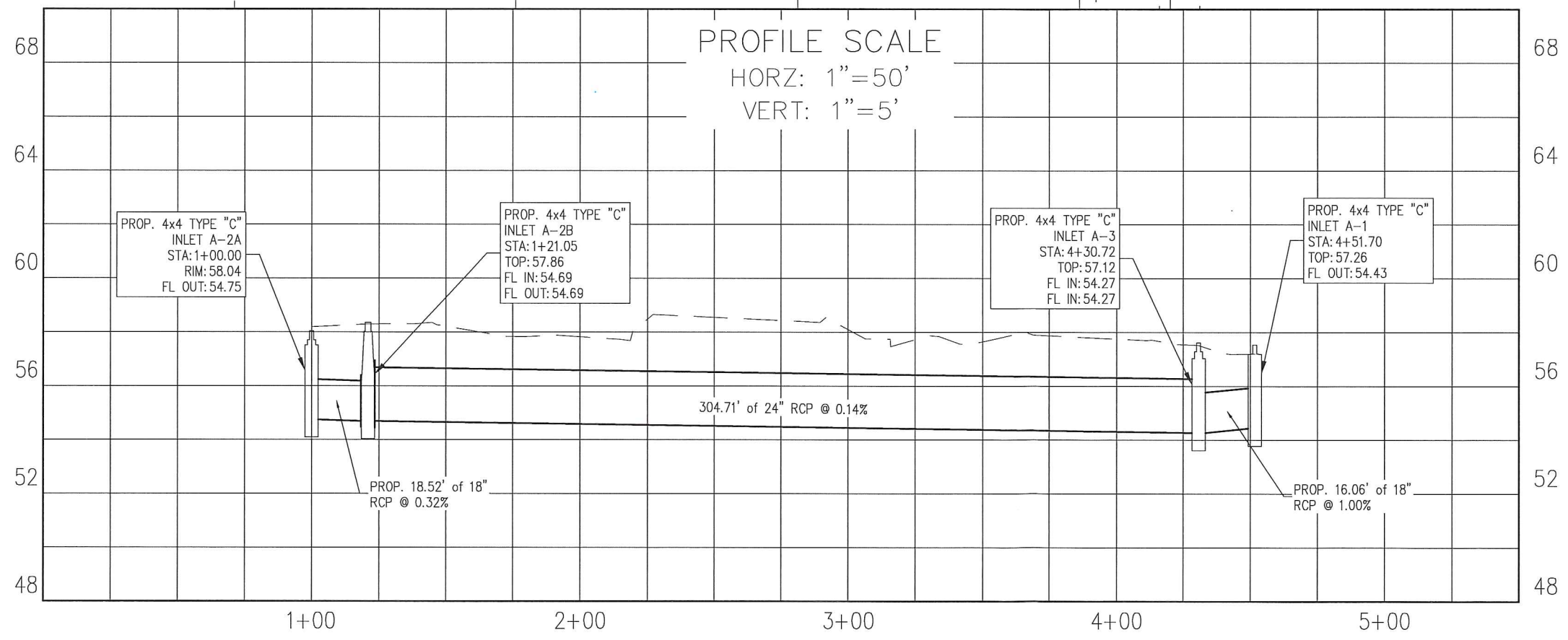
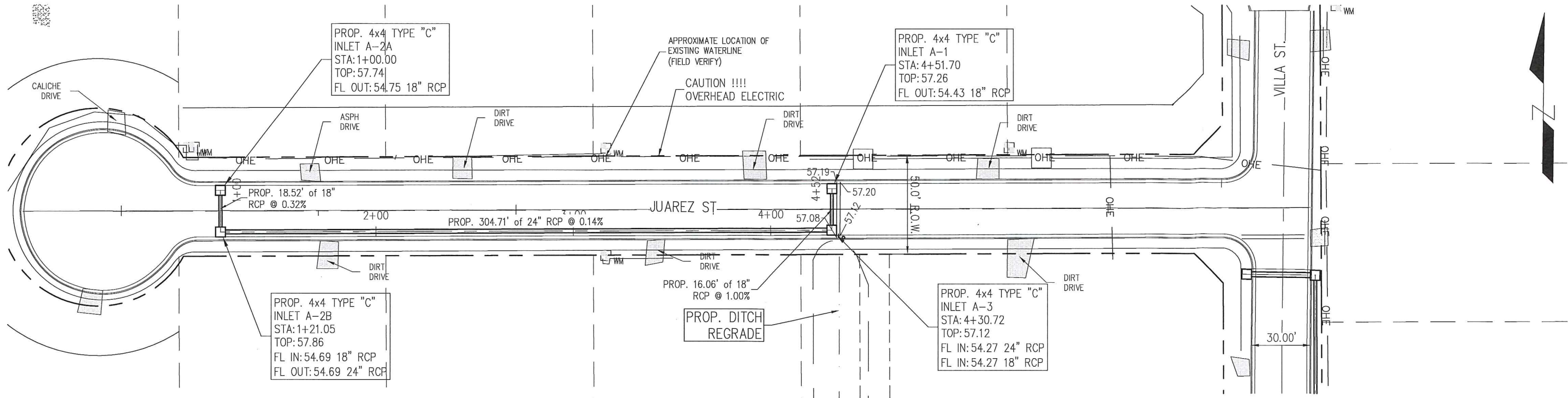

NO.	DESCRIPTION	INITIALS	DATE
1			
2			
3			
4		CAG	

THIS DOCUMENT IS RELEASED FOR INTERIM REVIEW ONLY UNDER AUTHORITY OF CRAIG A. GONZALEZ, P.E., (NO. 99268) ON 06/27/2016 AND IS NOT TO BE USED FOR BIDDING OR CONSTRUCTION.



407 N. SALINAS BLVD. (956) 464-4710  
 PO BOX 729 TBPE FIRM NO. F-13094  
 DONNA, TEXAS 78537 WWW.UIGTexas.COM

**JUAREZ ST  
DRAINAGE IMPROVEMENTS  
STA 1+00 TO END**

PROJECT NO.	112800
DATE:	6/27/2016
SCALE:	

SHEET NUMBER: **C10**

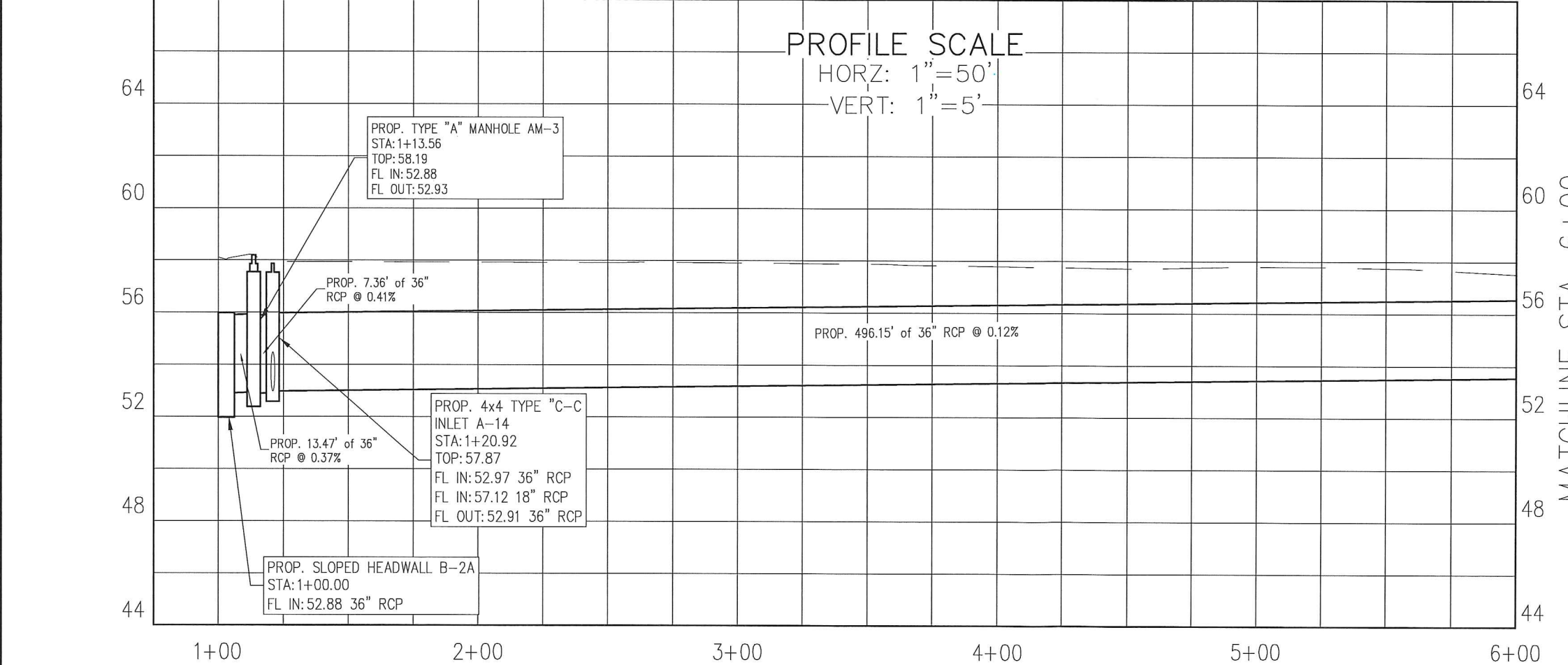
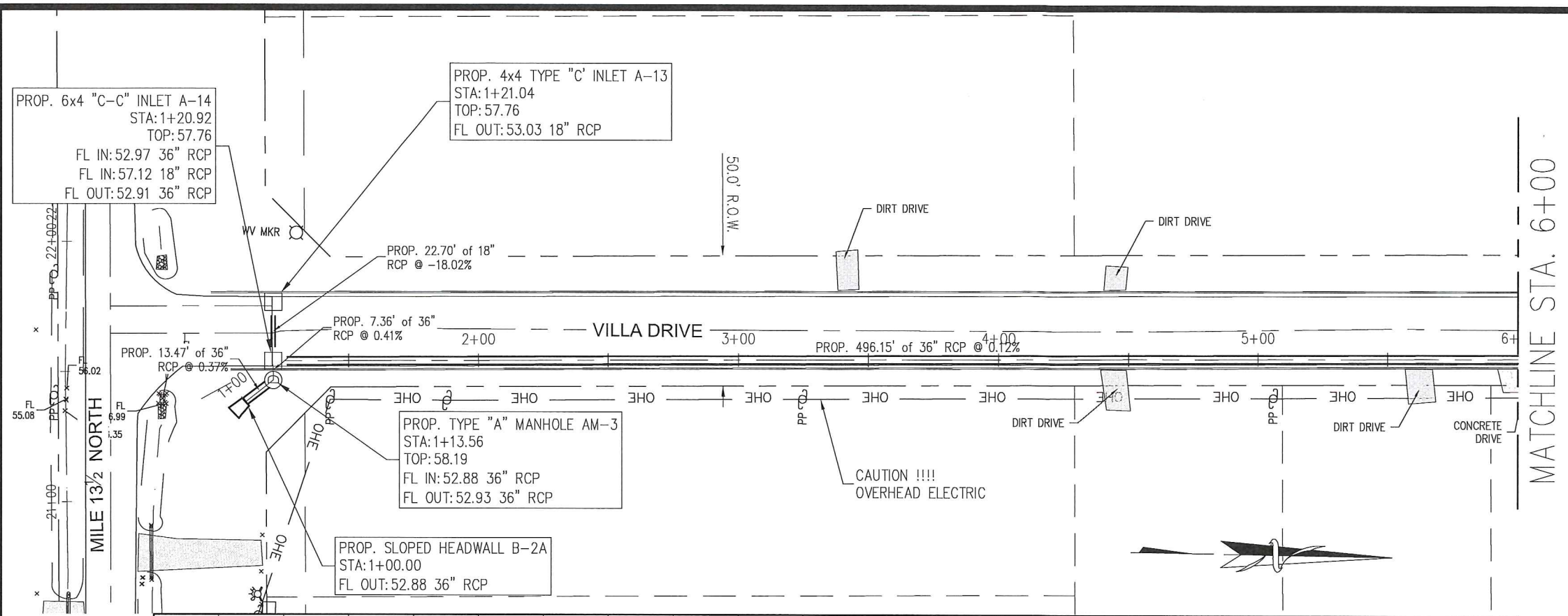

NO.	DESCRIPTION	INITIALS	DATE
1			
2			
3			
4		CAG	

THIS DOCUMENT IS RELEASED FOR INTERIM REVIEW ONLY UNDER AUTHORITY OF CRAIG A. GONZALEZ, P.E., (NO. 99268) ON 07/16 AND IS NOT TO BE USED FOR BIDDING OR CONSTRUCTION.

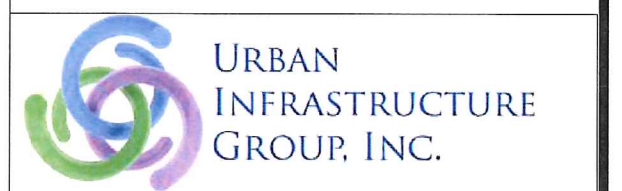

407 N. SALINAS BLVD. (956) 464-4710  
 PO BOX 729 TBPE FIRM NO. F-13094  
 DONNA, TEXAS 78537 WWW.UIGTexas.COM

**VILLA DR.  
 DRAINAGE IMPROVEMENTS  
 STA 1+00 TO 6+00**

PROJECT NO.	112800
DATE:	07/16
SCALE:	H 1"=50' V 1"=5'

SHEET NUMBER: **C8**

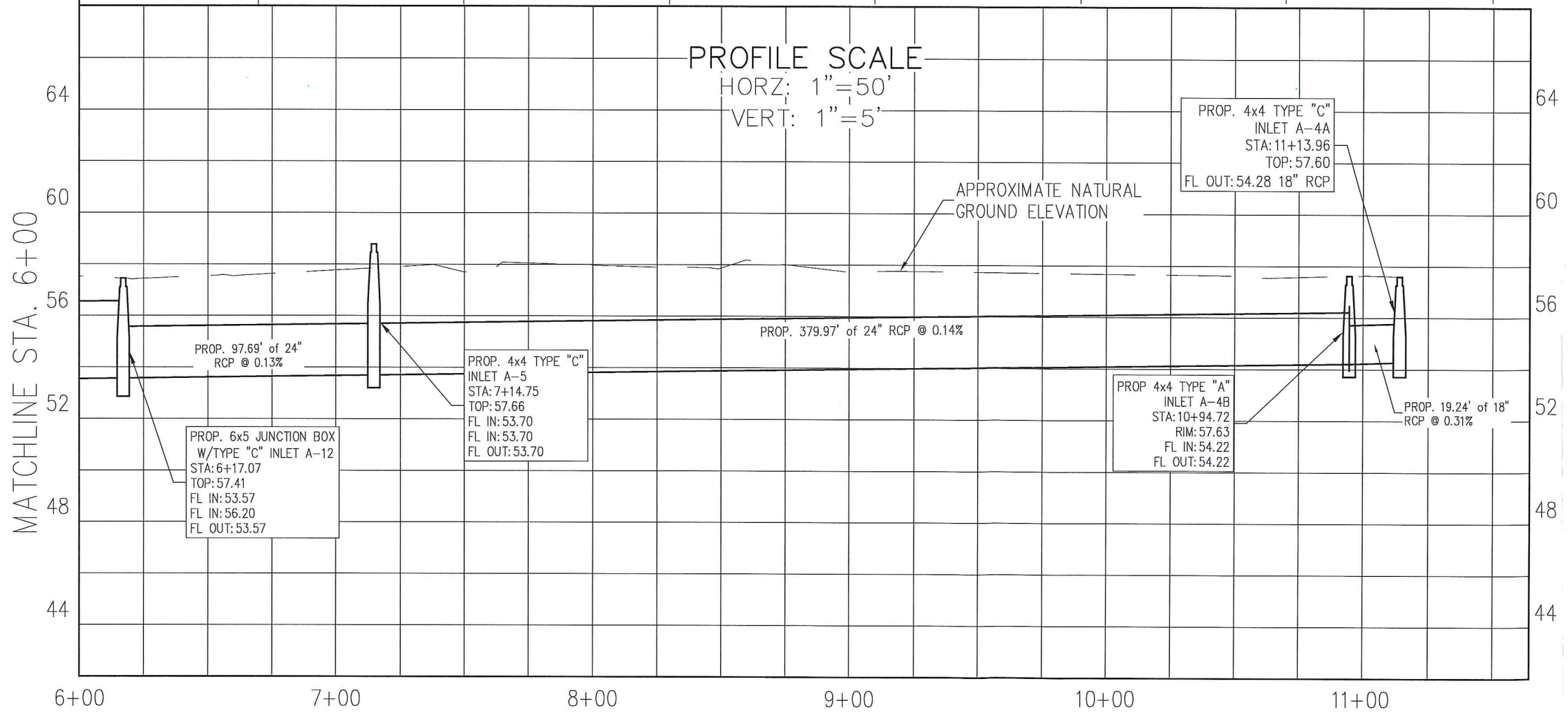
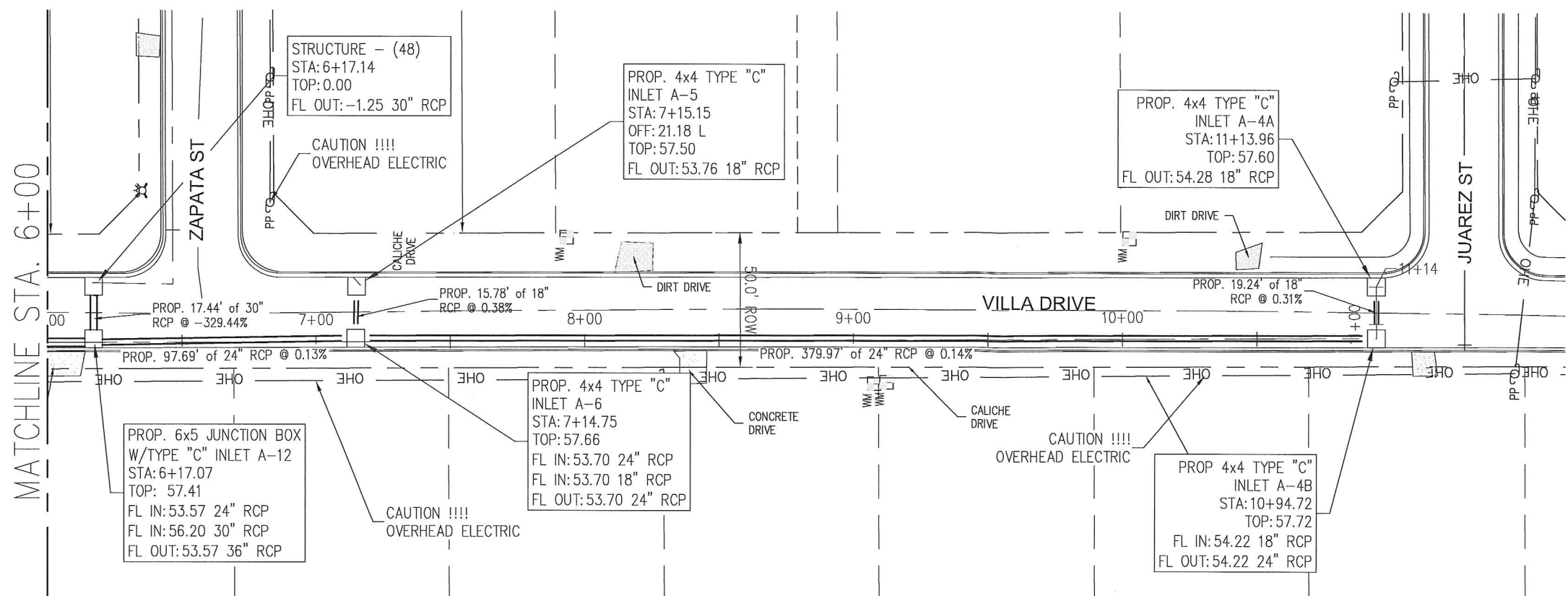

NO.	DESCRIPTION	INITIALS	DATE
1			
2			
3			
4		CAG	

THIS DOCUMENT IS RELEASED FOR INTERIM REVIEW ONLY UNDER AUTHORITY OF CRAIG A. GONZALEZ, P.E., (NO. 99268) ON 7/2016 AND IS NOT TO BE USED FOR BIDDING OR CONSTRUCTION.



407 N. SALINAS BLVD. (956) 464-4710  
PO BOX 729 TBPE FIRM NO. F-13094  
DONNA, TEXAS 78537 WWW.UIGTexas.COM

VILLA ST.  
DRAINAGE IMPROVEMENTS  
STA 6+00 TO END

PROJECT NO.	112800
DATE:	7/2016
SCALE:	

SHEET NUMBER: **C9**

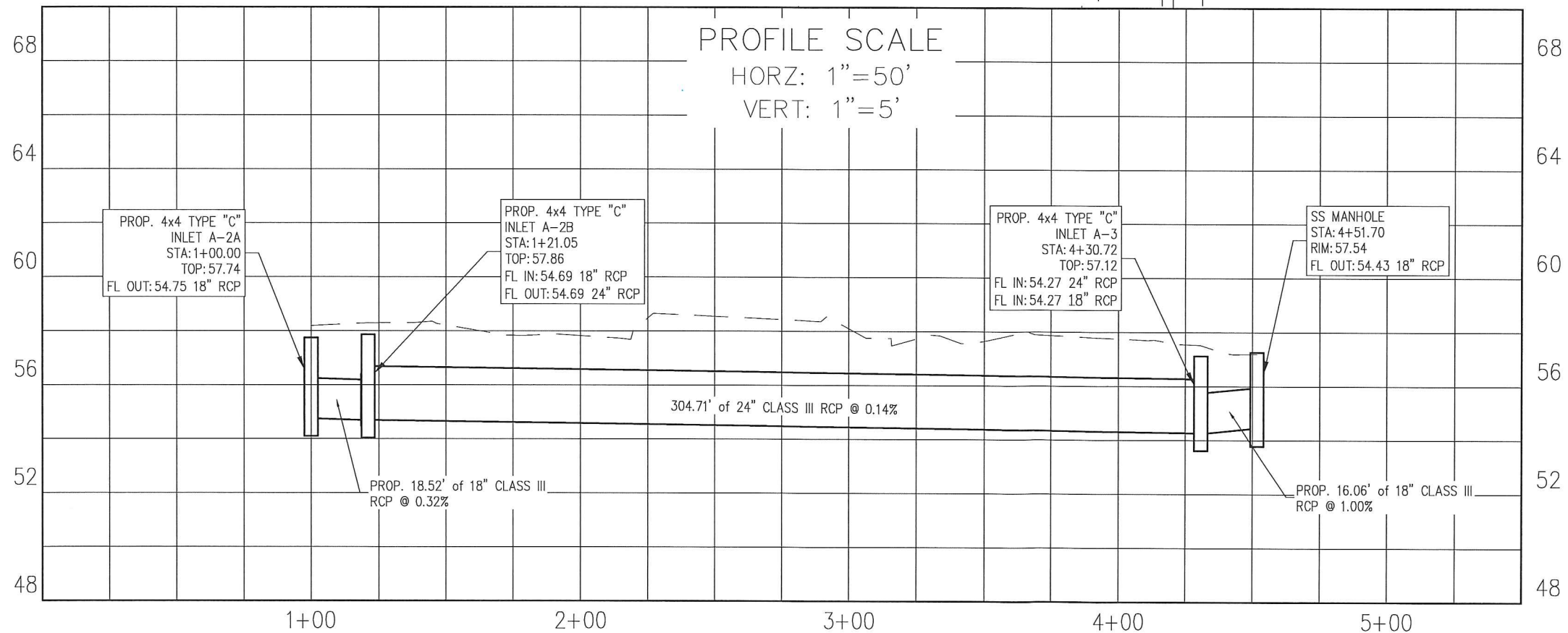
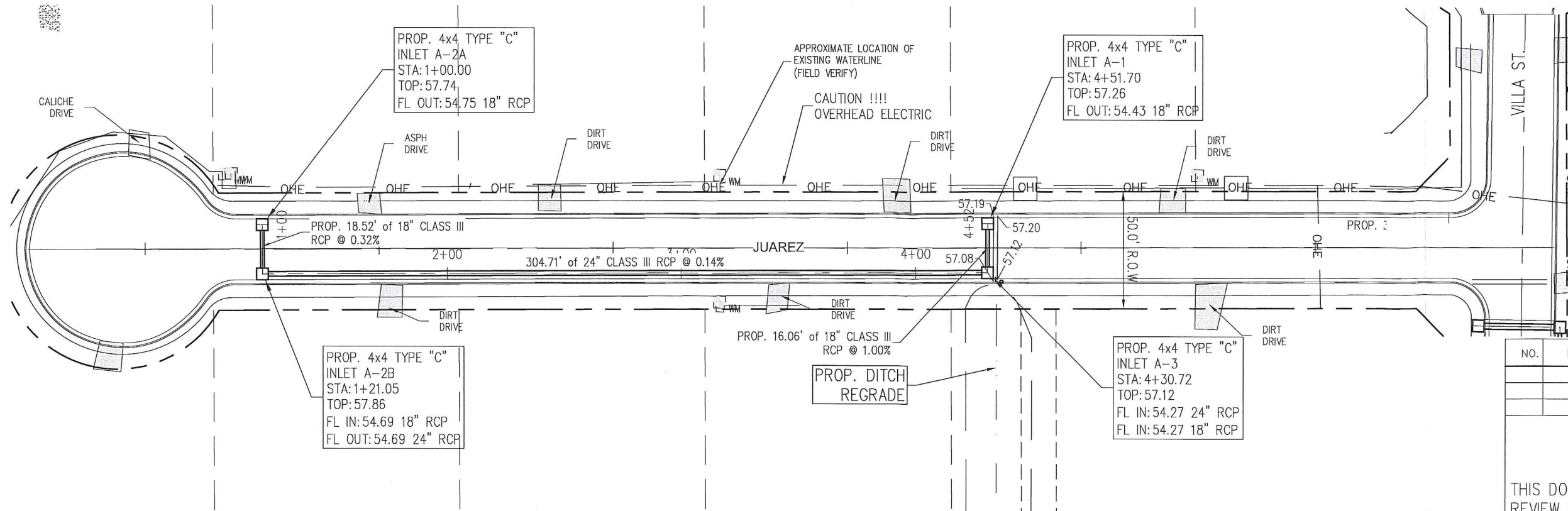

NO.	DESCRIPTION	INITIALS	DATE

THIS DOCUMENT IS RELEASED FOR INTERIM REVIEW ONLY UNDER AUTHORITY OF CRAIG A. GONZALEZ, P.E., (NO. 99268) ON 10/2016 AND IS NOT TO BE USED FOR BIDDING OR CONSTRUCTION.

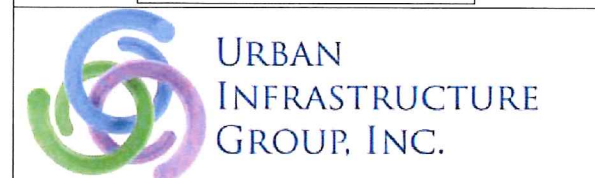

407 N. SALINAS BLVD. (956) 464-4710  
 PO BOX 729 TBPE FIRM NO. F-13094  
 DONNA, TEXAS 78537 WWW.UIGTexas.COM

**VILLA DR.  
 DRAINAGE IMPROVEMENTS  
 STA 1+00 TO 5+00**

PROJECT NO.	112800
DATE:	10/16
SCALE:	H 1"=50' V 1"=5'

SHEET NUMBER:

**C8**

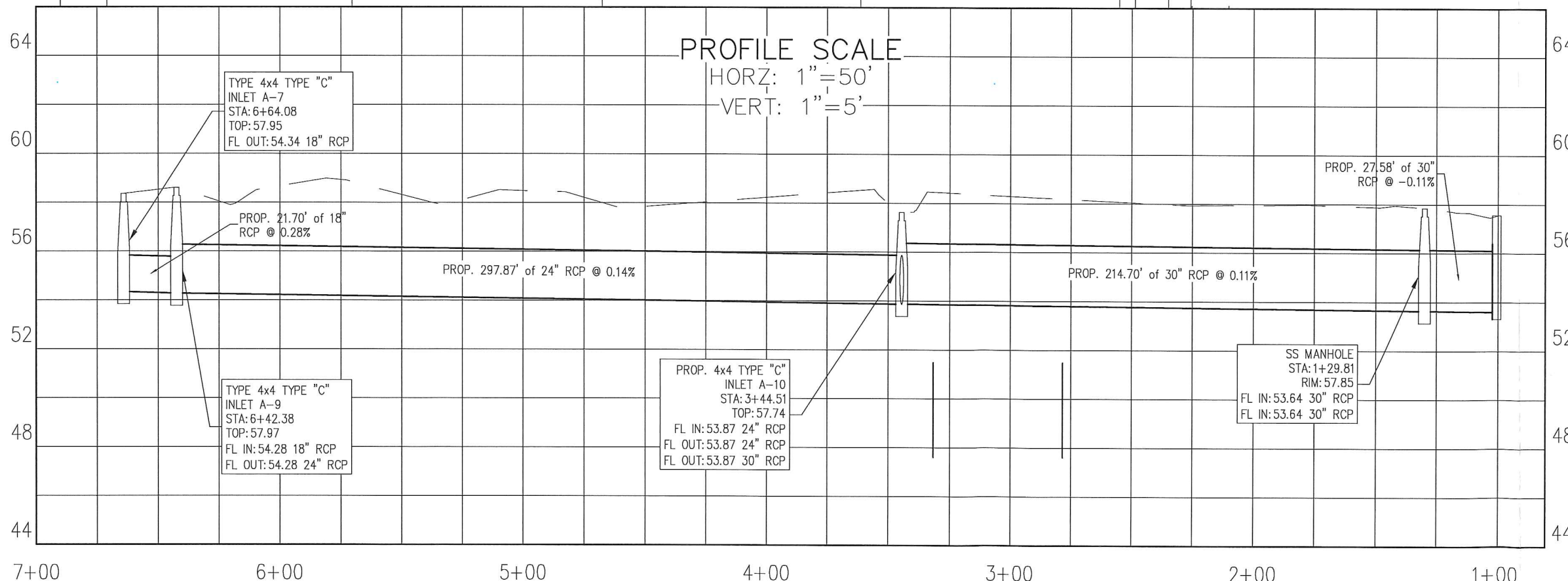
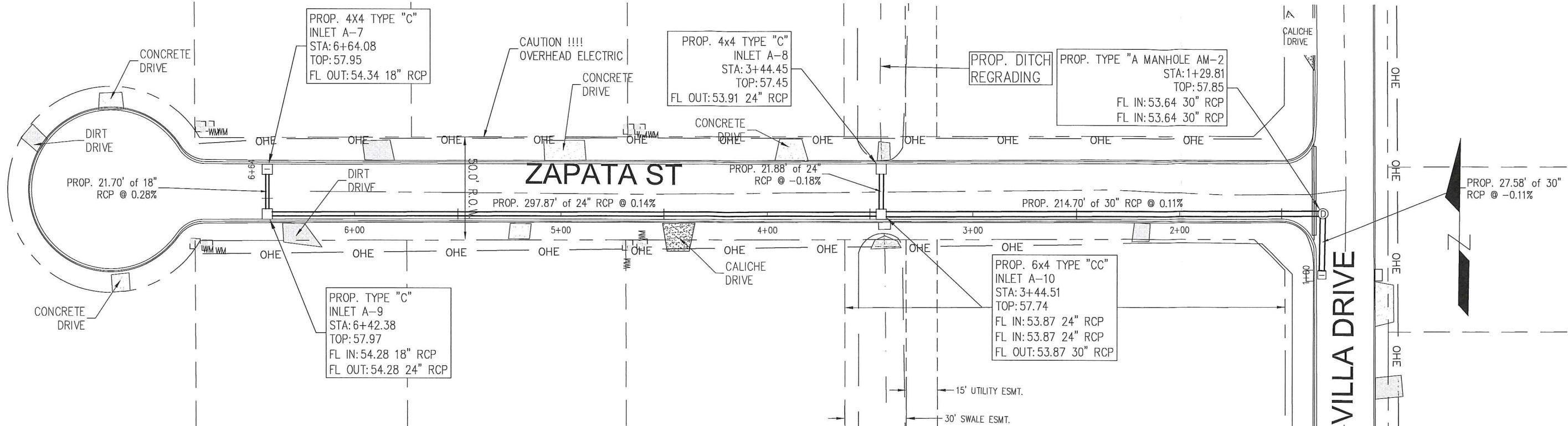

NO.	DESCRIPTION	INITIALS	DATE
1			
2			
3			
4		CAG	

THIS DOCUMENT IS RELEASED FOR INTERIM REVIEW ONLY UNDER AUTHORITY OF CRAIG A. GONZALEZ, P.E., (NO. 99268) ON 7/2016 AND IS NOT TO BE USED FOR BIDDING OR CONSTRUCTION.

**URBAN INFRASTRUCTURE GROUP, INC.**  
 407 N. SALINAS BLVD. (956) 464-4710  
 PO BOX 729 TBPE FIRM NO. F-13094  
 DONNA, TEXAS 78537 WWW.UIGTexas.COM

**ZAPATA ST.  
 DRAINAGE IMPROVEMENTS  
 STA 1+00 TO END**

PROJECT NO.	112800
DATE:	7/2016
SCALE:	

SHEET NUMBER: **C11**





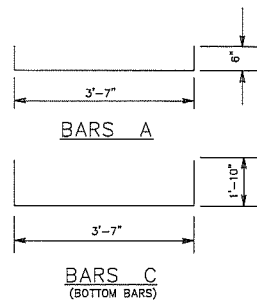
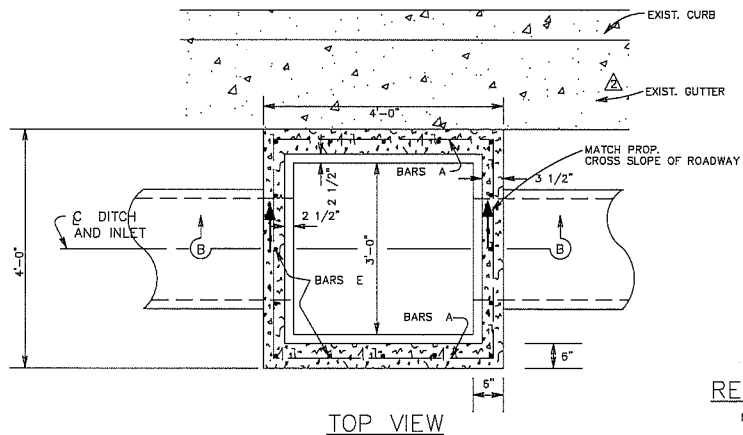

**REINFORCING STEEL DETAILS**

NOTE: ALL STEEL TO BE NO. 4 BARS ON 12" SPACING IN BOTH DIRECTIONS

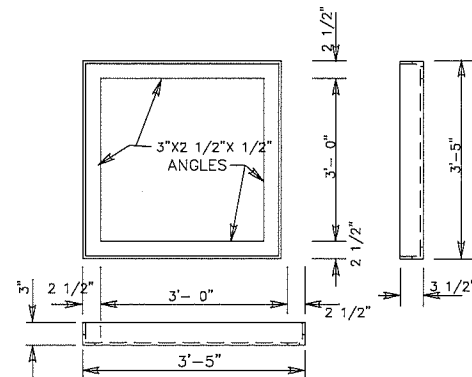

**FRAME DETAIL**

FRAME INLET GRATE TO BE SUBSIDIARY

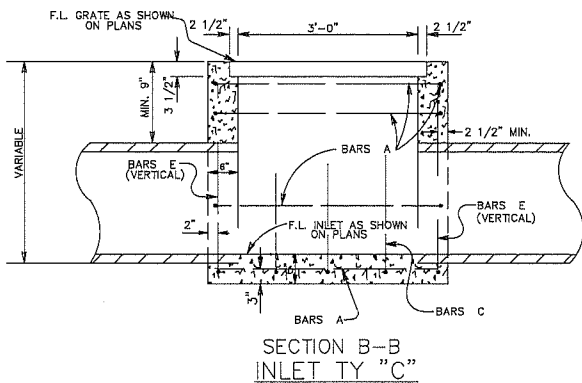

SECTION B-B  
INLET TY "C"

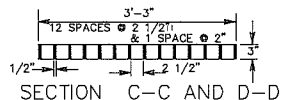
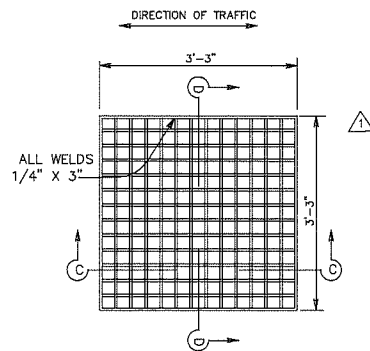

**WELDED STEEL INLET GRATE**

GENERAL NOTES:  
TY "C" INLET TO BE USED FOR PIPES LESS OR EQUAL TO 24"

TxDOT 2002 PHARR DISTRICT STANDARD

**TEXAS DEPARTMENT OF TRANSPORTATION**  
**TY "C" INLET DETAILS (MOD)**

REV. 4/02	INLET.C.DGN
FEDERAL AID PROJECT NO.	FILE NO.
STATE	COUNTY
TEXAS	HIDALGO

THIS DOCUMENT IS RELEASED FOR INTERIM REVIEW ONLY UNDER AUTHORITY OF CRAIG A. GONZALEZ, P.E. (NO. 99258) ON 10/18/2016 AND IS NOT TO BE USED FOR BIDDING OR CONSTRUCTION.

- △ REVISION: ADDED GRID GRATE
- △ REVISION: ADDED EXIST. CURB AND GUTTER AND PROP. CROSS SLOPE

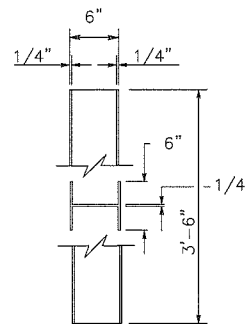
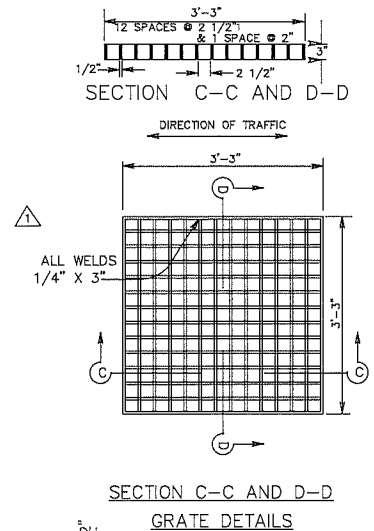
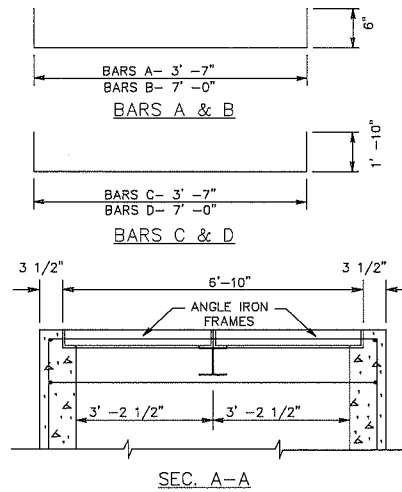
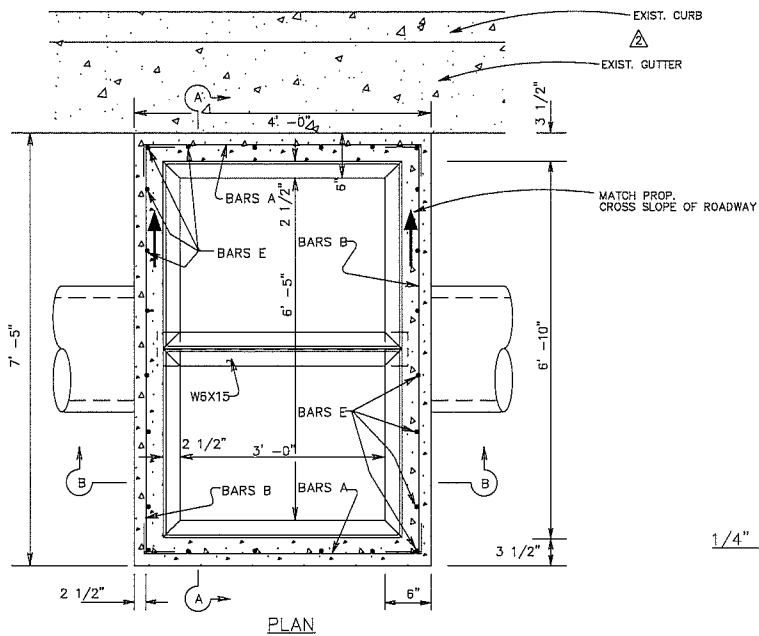

I-BEAM DETAILS  
W 6 X 15

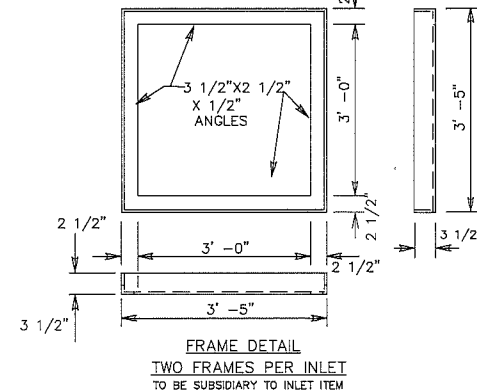

FRAME DETAIL  
TWO FRAMES PER INLET  
TO BE SUBSIDIARY TO INLET ITEM

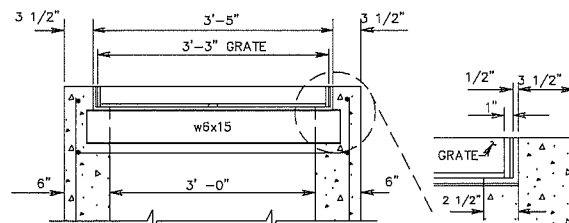
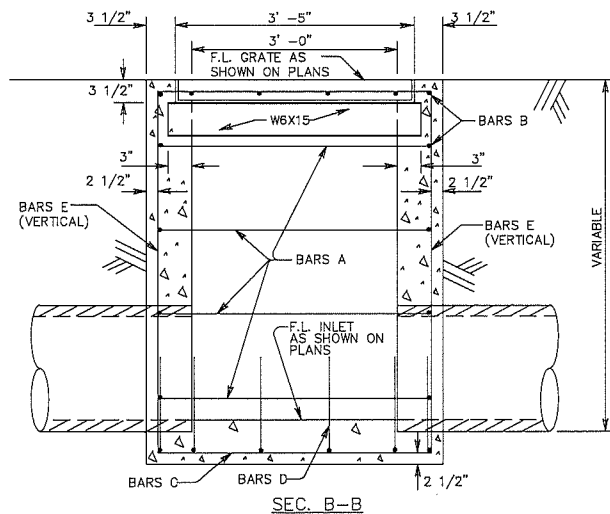

SECTION B-B  
(DETAIL W/GRATE)

NOTE: ALL STEEL REINFORCING TO BE NO. 4 BARS ON 1'-0" SPACING IN BOTH DIRECTIONS ALL STEEL TO BE GR. 60.

THIS DOCUMENT IS RELEASED FOR INTERIM REVIEW ONLY UNDER AUTHORITY OF CRAIG A. GONZALEZ, P.E., (NO. 99268) ON 10/18/2016 AND IS NOT TO BE USED FOR BIDDING OR CONSTRUCTION.

- ⚠ REVISION: ADDED GRID GRATE
- ⚠ REVISION: ADDED EXIST. CURB AND GUTTER AND PROP. CROSS SLOPE

© TxDOT 2004 PHARR DISTRICT STANDARD

**TEXAS DEPARTMENT OF TRANSPORTATION**  
INLET TY "CC"  
DETAIL (MOD)

REV. 03/04 INLETCC.DCN

PROJECT NO.	FILE NO.	PROJECT NO.	SHEET NO.
5			
STATE	STATE	COUNTY	CONTRACT
TEXAS	21	HIDALGO	



# Hidalgo County Drainage District No. 1

902 North Doolittle Road, Edinburg, TX 78542 Office: 956-292-7080

## Invoice Processing Routing Slip

Invoice/ Backup

Date Received: 11/7/2016

Engineer/Firm Name: Urban Infrastructure Group, Inc.

Project Name/Number: Pct.1 Mile 13.5 and 1015 Area DIP, WA No. 6

Invoice No.: 1116112806

Invoice Date: 11/4/2016

Due Date: 12/7/2016

Purchase Order No.: 630494

Amount: \$4,054.44

Total # of Pages Submitted: 4

Attachments:  CD  USB  Plans Other: \_\_\_\_\_

Engineering:

Construction:

Received By: Maria Perez

### Forwarded to:

Nora D. Cavazos \_\_\_\_\_ Date: \_\_\_\_\_

Esther Layton \_\_\_\_\_ Date: \_\_\_\_\_

Claudette Guerrero \_\_\_\_\_ Date: \_\_\_\_\_

Jose N. Saldivar \_\_\_\_\_ Date: \_\_\_\_\_

Lora Briones \_\_\_\_\_ Date: \_\_\_\_\_

Additional Comments: Eng. Srvs. for Villa Drive



URBAN  
INFRASTRUCTURE  
GROUP, INC.

November 4, 2016

RECEIVED  
HIDALGO COUNTY  
DRAINAGE DISTRICT #1

Jaime Salazar, Operations Manager  
Hidalgo County Drainage District No.1  
902 N. Doolittle  
Edinburg, Texas 78542

NOV 07 2016

4:30 AM/PM

BY: MAP

RE: Invoice No. 1116112806

Project Name:	Pct. 1 – Mile 13 ½ and 1015 area Drainage Improvement Project Work Authorization No. 6 – Engineering Services for Villa Drive
Project Number:	112806

Invoice Period:	October 2016
-----------------	--------------

This invoice is for engineering services pertaining to the Los Olivarez Acres Drain to Ditch 4E2A project Work Authorization No. 6. The Attached with this invoice is our Monthly Progress Report. Below shows the amount billed for this period. If you have any questions please don't hesitate to call me.

	Complete This Month	Contract Amount	Amount This Month	Total
<b>Professional Services</b>				
WA#6 PO 630494 (50% Complete)	50%	\$8,108.87	\$4,054.44	\$4,054.44

<b>TOTAL AMOUNT DUE:</b>	<b>\$4,054.44</b>
--------------------------	-------------------

*I certify that the above information is true and correct.*

Craig A Gonzalez, P.E.  
Principal

*We appreciate the opportunity to serve you on this project.  
God Bless.*

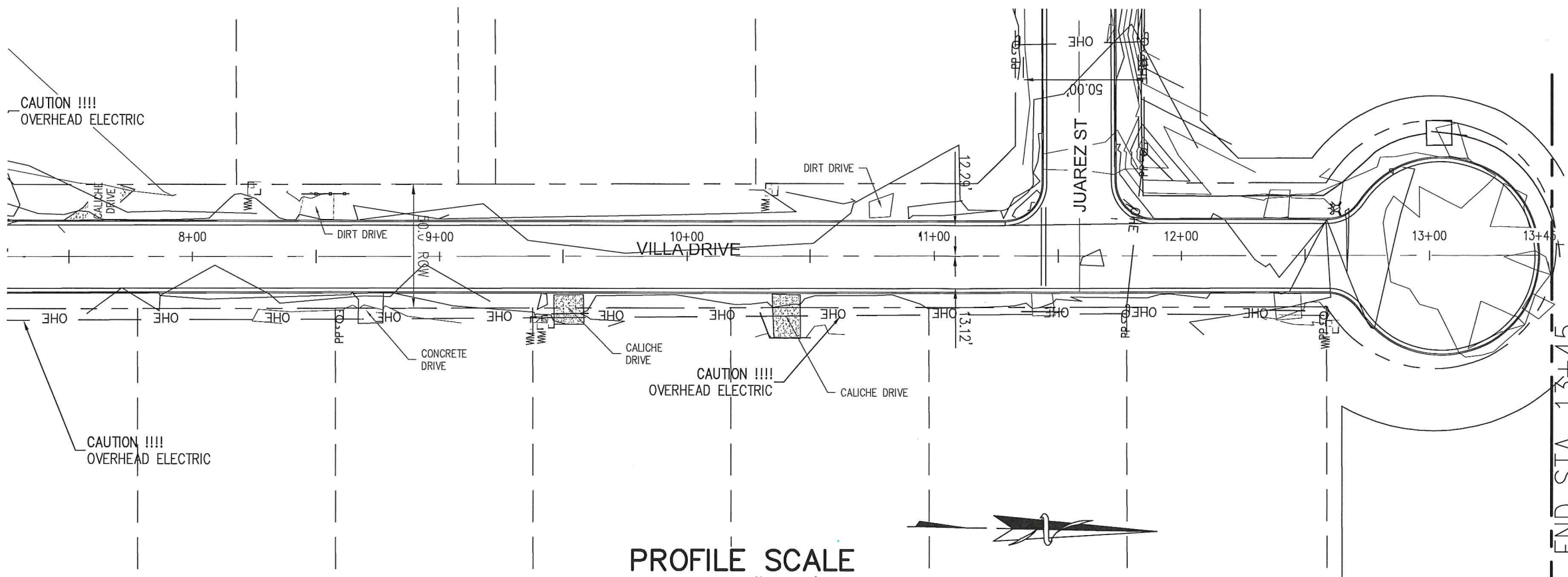

**PROFILE SCALE**  
 HORZ: 1"=50'  
 VERT: 1"=5'

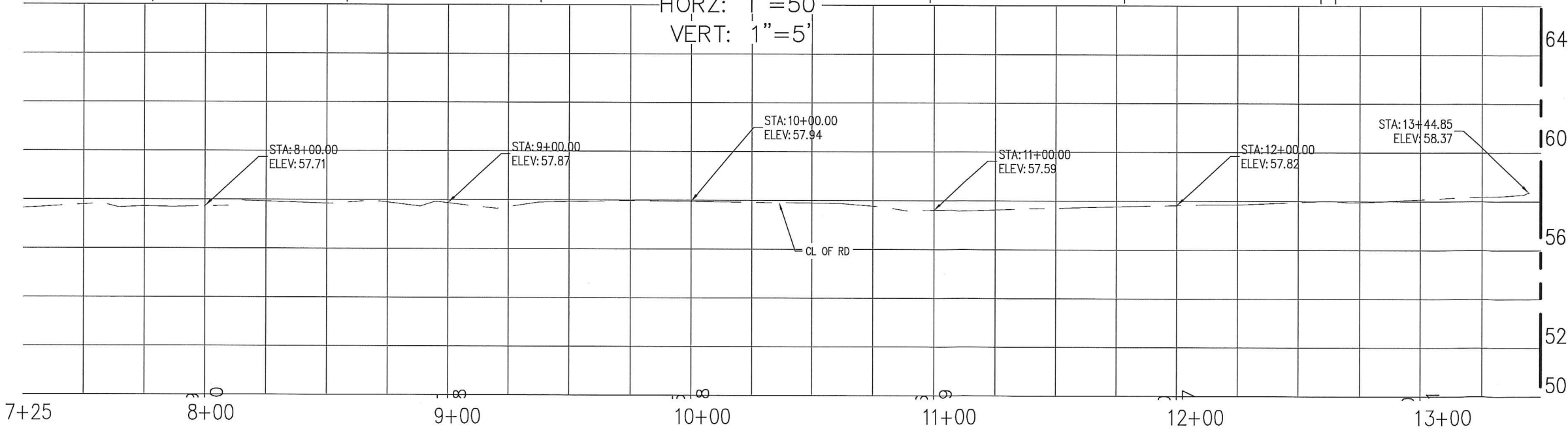

END STA. 13+45

THIS DOCUMENT IS RELEASED FOR INTERIM REVIEW ONLY UNDER AUTHORITY OF CRAIG A. GONZALEZ, P.E., (NO. 99268) ON 10/16 AND IS NOT TO BE USED FOR BIDDING OR CONSTRUCTION.

NO.	DESCRIPTION	INITIALS	DATE
1			
2			
3			
4		CAG	

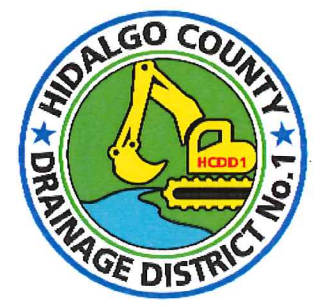

407 N. SALINAS BLVD. (956) 464-4710  
 PO BOX 729 TBPE FIRM NO. F-13094  
 DONNA, TEXAS 78537 WWW.UIGTexas.COM

**VILLA DR.  
 PAVING IMPROVEMENTS  
 STA 7+25 TO END STA 13+45**

PROJECT NO.	112800
DATE:	10/16
SCALE:	H 1"=50' V 1"=5'

SHEET NUMBER:  
C2

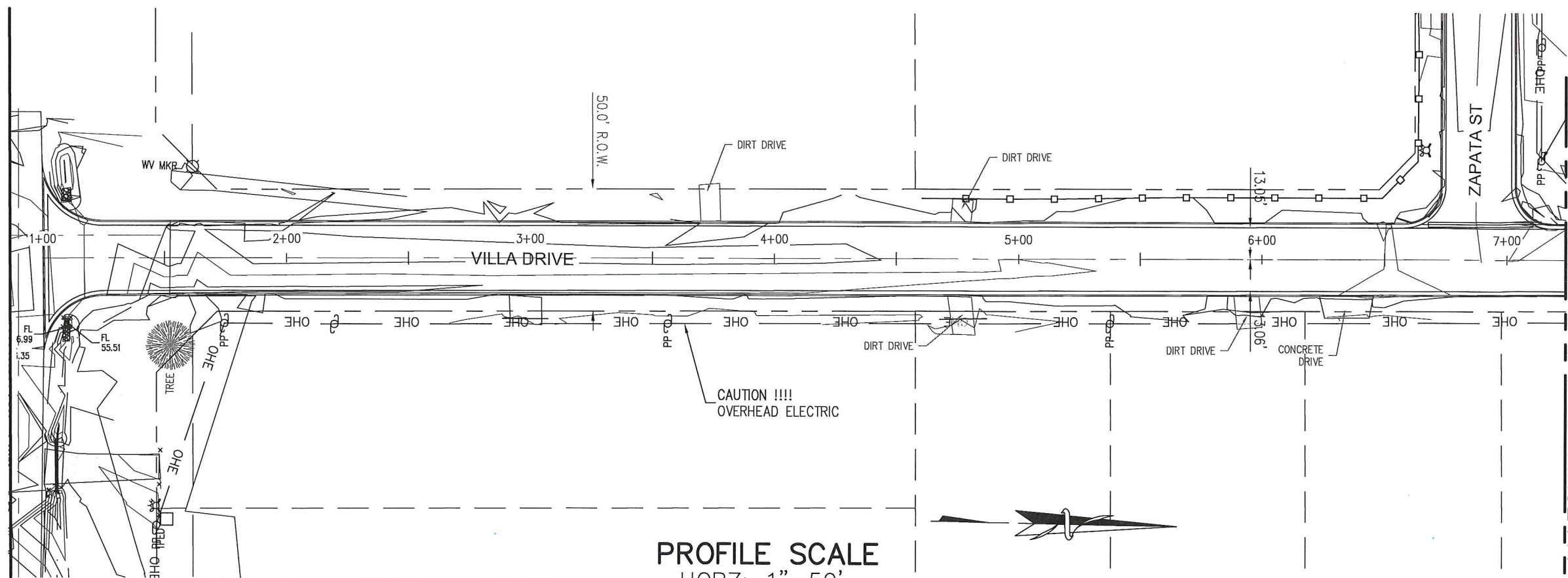

**PROFILE SCALE**  
 HORZ: 1"=50'  
 VERT: 1"=5'

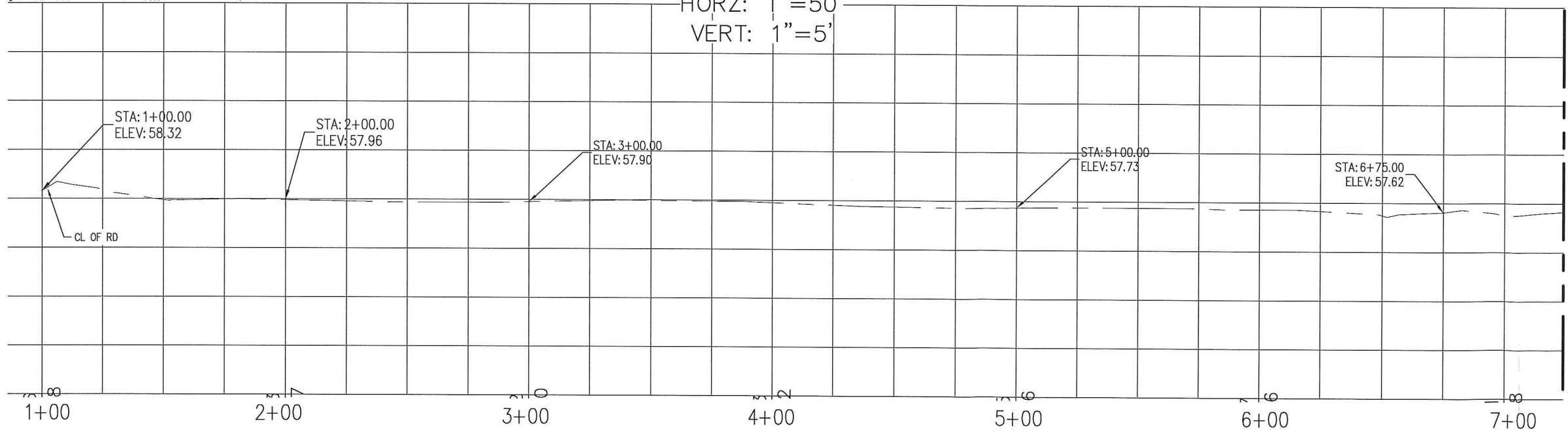

MATCHLINE STA. 7+25

THIS DOCUMENT IS RELEASED FOR INTERIM REVIEW ONLY UNDER AUTHORITY OF CRAIG A. GONZALEZ, P.E., (NO. 99268) ON 10/16 AND IS NOT TO BE USED FOR BIDDING OR CONSTRUCTION.

NO.	DESCRIPTION	INITIALS	DATE
1			
2			
3			
4		CAG	



407 N. SALINAS BLVD. (956) 464-4710  
 PO BOX 729 TBPE FIRM NO. F-13094  
 DONNA, TEXAS 78537 WWW.UIGTexas.COM

**VILLA DR.  
 PAVING IMPROVEMENTS  
 STA 1+00 TO 7+00**

PROJECT NO.	112800
DATE:	10/16
SCALE:	H 1"=50' V 1"=5'

SHEET NUMBER:  
C1



**AI -57455**

**6.**

**DRAINAGE - CONSENT**

Meeting Date: 11/22/2016

Submitted For: Lora Briones

Submitted By: Claudette Guerrero,  
DRAINAGE DISTRICT

Department: DRAINAGE DISTRICT

---

Information

CAPTION

General Fund

Budget 006-M&O

Invoice No. M217472 in the amount of \$82,904.86 from Halff & Associates, Inc.  
Pertaining to WA#2-Engineering Services for Firing Range.  
PO#629455

BACKGROUND

---

Fiscal Impact

Attachments

Halff Inv#M217472

---

**Form Review**

**Inbox**

**Reviewed By**

**Date**

Final Approval

Monica Badillo

11/18/2016 05:28 PM

Form Started By: Claudette Guerrero

Started On: 11/18/2016 02:07 PM

Final Approval Date: 11/18/2016



# Hidalgo County Drainage District No. 1

902 North Doolittle Road, Edinburg, TX 78542 Office: 956-292-7080

## Invoice Processing Routing Slip

Invoice/ Backup

Date Received: 10/24/2016

Engineer/Firm Name: Halff Associates, Inc.

Project Name/Number: Former Firing Range Berm, WA No. 2

Invoice No.: M217472

Invoice Date: 10/20/2016

Due Date: 11/23/2016

Purchase Order No.: 629455

Amount: \$82,904.86

Total # of Pages Submitted: 10

Attachments:  CD  USB  Plans Other: \_\_\_\_\_ 5

Engineering:  Construction:

Received By: Maria Perez

### Forwarded to:

Nora D. Cavazos \_\_\_\_\_ Date: \_\_\_\_\_

Esther Layton \_\_\_\_\_ Date: \_\_\_\_\_

Claudette Guerrero \_\_\_\_\_ Date: \_\_\_\_\_

Jose N. Saldivar \_\_\_\_\_ Date: \_\_\_\_\_

Lora Briones \_\_\_\_\_ Date: \_\_\_\_\_

Additional Comments: \_\_\_\_\_

RECEIVED  
HIDALGO COUNTY  
DRAINAGE DISTRICT #1

RECEIVED  
HIDALGO COUNTY  
DRAINAGE DISTRICT #1

OCT 24 2016

OCT 24 2016

2:06 AM (PM)

2:06 AM (PM)

BY: *[Signature]*

BY: *[Signature]*

# INVOICE

# HALFF

ENGINEERS ARCHITECTS SCIENTISTS PLANNERS SURVEYORS

## REMITTANCE ADDRESS

**Halff Associates, Inc**  
**P.O. Box 678316**  
**Dallas, TX 75267**  
**www.halff.com**

**HIDALGO COUNTY DRAINAGE DISTRICT #1**  
**902 N. DOOLITTLE**  
**EDINBURG, TX 78542**  
**Attention: Mr. Raul Sesin**

**Invoice Date :** 10/20/2016  
**Invoice # :** M217472  
**Project :** 31392  
**Invoice Group :** 02  
**Client Code :** HIDALG

**Project Name :** HCDD#1\Former Firing Range Berm

**For Professional Services Rendered through: 10/16/2016**

Re: Engineering Services \ Subsurface Investigation  
Rifle\Handgun Firing Range Project  
TCEQ TRRP Applicability Evaluation & Environmental Remediation  
Edinburg, TX  
Purchase Order#: 629455

\*\* Please contact Maribel Martinez at (956-664-0286)  
with any questions regarding this invoice.

Phase / Task / Name	Fee	Previous Amount	Current Amount	Total Fee Earned	Budget Remaining
WA02 -- TCEQ TRRP Applicability& Remediatio	151,788.00	38,360.82	82,904.86	121,265.68	30,522.32
<b>Totals:</b>	<b>151,788.00</b>	<b>38,360.82</b>	<b>82,904.86</b>	<b>121,265.68</b>	<b>30,522.32</b>

Project Fee: 151,788.00  
Prior Billings: 38,360.82  
Total Available: 113,427.18

Total this Invoice 82,904.86  
**Amount Due this Invoice 82,904.86**

*Thank you*  
*[Signature]*

Phase :WA02 -- TCEQ TRRP Applicability&amp; Remediatio

Task : \*\*\*\* -- Default Task

## Rate Schedule Labor

<u>Class / Employee Name</u>	<u>Date</u>	<u>Hours</u>	<u>Rate</u>	<u>Amount</u>
<b>GEOLOGIST</b>				
S Kent Belaire	09/13/2016	0.50	205.00	102.50
	09/16/2016	0.50	205.00	102.50
	09/20/2016	1.00	205.00	205.00
	09/21/2016	0.50	205.00	102.50
	09/23/2016	0.50	205.00	102.50
	09/30/2016	2.00	205.00	410.00
	10/04/2016	2.00	205.00	410.00
	10/05/2016	1.50	205.00	307.50
	10/06/2016	1.00	205.00	205.00
	10/07/2016	4.00	205.00	820.00
	10/10/2016	1.00	205.00	205.00
		-----		-----
		14.50		2,972.50
<b>GEOLOGIST, GRADE 3</b>				
Austin C. Harrison	09/07/2016	2.00	90.00	180.00
Worked on coordinating timing for soil removal & water well search				
	09/08/2016	2.00	90.00	180.00
Worked on coordinating timing for soil removal & water well search				
	09/16/2016	1.00	90.00	90.00
Coordinated with Sunbelt on profile needs for berm removal				
	09/20/2016	1.00	90.00	90.00
Worked on getting waste profiles signed for Hidalgo County Berm with Sunbelt				
	09/22/2016	1.00	90.00	90.00
Worked on scheduling Hidalgo County Berm with Sunbelt				
	09/23/2016	1.00	90.00	90.00
Postponed Hidalgo County berm removal. Cancelled reservations and worked on re-scheduling with Sunbelt.				
	09/26/2016	2.00	90.00	180.00
Worked on prepping and coordinating for Hidalgo berm removal next week.				
	09/27/2016	2.00	90.00	180.00
Worked on prepping and coordinating for Hidalgo berm removal next week.				
	09/28/2016	2.00	90.00	180.00
Worked on prepping and coordinating for Hidalgo berm removal next week.				
	09/29/2016	2.00	90.00	180.00
Worked on prepping and coordinating for Hidalgo berm removal next week.				
	09/30/2016	2.00	90.00	180.00
Worked on prepping and coordinating for Hidalgo berm removal next week.				
	10/03/2016	8.00	90.00	720.00

## Phase :WA02 -- TCEQ TRRP Applicability&amp; Remediatio

Task : \*\*\*\* -- Default Task

## Rate Schedule Labor

<u>Class / Employee Name</u>	<u>Date</u>	<u>Hours</u>	<u>Rate</u>	<u>Amount</u>
<b>GEOLOGIST, GRADE 3</b>				
Drove to Edinburg, reconned site.	10/04/2016	8.00	90.00	720.00
Excavated one load for feasibility study at Landfill. Excavated original amount, and collected floor and wall samples from over excavated areas	10/05/2016	4.00	90.00	360.00
completed excavation activities.	10/06/2016	8.00	90.00	720.00
Loaded Trucks for landfill	10/07/2016	8.00	90.00	720.00
Loaded Trucks for landfill	10/10/2016	6.00	90.00	540.00
	10/11/2016	6.00	90.00	540.00
	10/14/2016	8.00	90.00	720.00
		-----		-----
		74.00		6,660.00
<b>GEOLOGIST, GRADE 5</b>				
Lee E. Beeson	09/06/2016	4.50	120.00	540.00
APAR, figure review	09/07/2016	2.00	120.00	240.00
Scheduling soil removal	09/08/2016	1.00	120.00	120.00
Scope review	09/09/2016	3.00	120.00	360.00
Project discussion with CH, APAR	09/12/2016	2.00	120.00	240.00
Schedule, Contact HCDD1 on removal	09/13/2016	3.50	120.00	420.00
APAR	09/14/2016	4.00	120.00	480.00
APAR	09/16/2016	1.00	120.00	120.00
Contact HCDD1, discuss removal with CH	09/19/2016	0.50	120.00	60.00
Soil removal questions	09/21/2016	1.50	120.00	180.00
Removal questions, APAR	09/22/2016	4.50	120.00	540.00
APAR	09/23/2016	3.50	120.00	420.00
APAR	09/27/2016	1.00	120.00	120.00
Discuss soil removal	09/29/2016	2.50	120.00	300.00
APAR	09/30/2016	4.50	120.00	540.00
Discuss soil removal with KB and CH, proof draft APAR	10/03/2016	3.00	120.00	360.00

Phase :WA02 -- TCEQ TRRP Applicability& Remediatio

Task : \*\*\*\* -- Default Task

Rate Schedule Labor

<u>Class / Employee Name</u>	<u>Date</u>	<u>Hours</u>	<u>Rate</u>	<u>Amount</u>
<b>GEOLOGIST, GRADE 5</b>				
APAR edits	10/04/2016	1.50	120.00	180.00
Questions on removal	10/06/2016	1.00	120.00	120.00
Review analytical data and QC data	10/10/2016	3.00	120.00	360.00
Discuss removal and extent of area, APAR	10/11/2016	1.50	120.00	180.00
APAR		-----		-----
		49.00		5,880.00
<b>SECRETARY</b>				
Shelly P. Stancill	09/20/2016	0.50	60.00	30.00
Travel arrangements - C. Harrison	10/04/2016	0.50	60.00	30.00
Travel arrangements - Harrison		-----		-----
		1.00		60.00
<b>Rate Schedule Labor</b>				<b>15,572.50</b>

Regular Expenses

<u>Vendor Name</u>	<u>Doc Nbr</u>	<u>Date</u>	<u>Cost</u>	<u>Multiplier</u>	<u>Amount</u>
<b>Testing</b>					
B&A Laboratories, Inc.	204239	07/14/2016	(1) 220.000	1.100	242.00
	204242	07/15/2016	(2) 150.000	1.100	165.00
			-----		-----
			370.000		407.00
<b>Lodging</b>					
AMERICAN EXPRESS	204153	10/05/2016	(3) 336.740	1.100	370.41
Lodging - C. Harrison 10/3 - 10/4					
<b>Regular Expenses</b>					<b>777.41</b>

Total Task : \*\*\*\* -- Default Task

Labor : 15,572.50  
Expense : 777.41

Task : SUB01 -- Sunbelt Industrial

Regular Expenses

<u>Vendor Name</u>	<u>Doc Nbr</u>	<u>Date</u>	<u>Cost</u>	<u>Multiplier</u>	<u>Amount</u>
<b>Subconsultants - Other</b>					
Sunbelt Industrial Services	204314	10/20/2016	(4) 59,705.000	1.100	65,675.50
<b>Regular Expenses</b>					<b>65,675.50</b>

Total Task : SUB01 -- Sunbelt Industrial

Labor : 0.00  
Expense : 65,675.50

Task : SUB02 -- Test America Lab

Phase :WA02 -- TCEQ TRRP Applicability& Remediatio

Task : SUB02 -- Test America Lab

**Regular Expenses**

<u>Vendor Name</u>	<u>Doc Nbr</u>	<u>Date</u>	<u>Cost</u>	<u>Multiplier</u>	<u>Amount</u>
<b>Testing</b>					
TestAmerica Laboratories,	204122	10/17/2016	(5) 799.500	1.100	879.45
<b>Regular Expenses</b>					<b>879.45</b>

Total Task : SUB02 -- Test America Lab

Labor : 0.00  
Expense : 879.45

**Total Phase : WA02 -- TCEQ TRRP Applicability& Remediatio 82,904.86**

**Total Project: 31392 -- HCDD#1\Former Firing Range Berm 82,904.86**



PO Box 2256  
 Stafford, TX 77497  
 Ph: (281) 240-4200 Fax (281) 240-4280  
 Houston - Dallas - San Antonio - Midland  
 ACH: Routing: 26-708-4131  
 Bank Account: 12-871-1560

(1)

Invoice No. 1362050

204239

6/20/16

Please note our remit to address has changed

Client Information	Invoice Information
<b>Invoice to:</b> Halff Associates <b>Contact:</b> Kent Belaire <b>Address:</b> 1201 N. Bowser Richardson, TX 75081 <b>Project Name:</b> Edinburg Tx <b>Project #:</b> 31392/WA02	<b>Invoice Date:</b> 07.14.16 <b>Due Date:</b> 08.13.16 <b>Terms:</b> 30 Days <b>PO #:</b> <b>Lab PM:</b> Gale Denman

Comments:

Products / Services	WO Number	Matrix	TAT	Qty	Price	Ext. Price
Metals per ICP by SW846 6010B	533089	Solid	Standard TAT	4	50.00	\$200.00
Percent Moisture by SM2540G	533089	Solid	Standard TAT	4	5.00	\$20.00

**Total: \$220.00**

10/20

LB

Please detach this portion and return with your payment

Client Information
<b>Client:</b> Halff Associates <b>Contact:</b> Kent Belaire <b>Terms:</b> 30 Days <b>PO #:</b>

Invoice Information: 1362050
<b>Work Order Number:</b> 533089 <b>Due Date:</b> 08.13.16 <b>Invoice Amount:</b> \$220.00 <b>Amount Remitted:</b> <input type="text"/>

Past Due Invoices are subject to a 1.5% per Month service charge, plus collection fees.

Please send your payments to: B&A Laboratories, Inc.  
 PO Box 2256  
 Stafford, TX 77497  
 Ph: (281) 240-4200 Fax (281) 240-4280  
 Houston - Dallas - San Antonio - Odessa  
 ACH: Routing: 26-708-4131 Bank Account: 12-871-1560

**Make checks payable or Credit Card payments to B&A Laboratories, Inc.**



PO Box 2256  
 Stafford, TX 77497  
 Ph: (281) 240-4200 Fax (281) 240-4280  
 Houston - Dallas - San Antonio - Midland  
 ACH: Routing: 26-708-4131  
 Bank Account: 12-871-1560

(2)

Invoice No. 1362140

204242

Please note our remit to address has changed

6243

Client Information	Invoice Information
<b>Invoice to:</b> Halff Associates <b>Contact:</b> Kent Belaire <b>Address:</b> 1201 N. Bowser Richardson, TX 75081 <b>Project Name:</b> Edinburg, Tx <b>Project #:</b> 31392/WA02	<b>Invoice Date:</b> 07.15.16 <b>Due Date:</b> 08.14.16 <b>Terms:</b> 30 Days <b>PO #:</b> <b>Lab PM:</b> Gale Denman

Comments:

Products / Services	WO Number	Matrix	TAT	Qty	Price	Ext. Price
Metals per ICP by SW846 6010B	533090	Water	Standard TAT	3	50.00	\$150.00
<b>Total:</b>						<b>\$150.00</b>

10/19

KB

Please detach this portion and return with your payment

Client Information
<b>Client:</b> Halff Associates <b>Contact:</b> Kent Belaire <b>Terms:</b> 30 Days <b>PO #:</b>

Invoice Information: 1362140
<b>Work Order Number:</b> 533090 <b>Due Date:</b> 08.14.16 <b>Invoice Amount:</b> \$150.00 <b>Amount Remitted:</b> <input type="text"/>

Past Due Invoices are subject to a 1.5% per Month service charge, plus collection fees.

Please send your payments to: B&A Laboratories, Inc. d/b/a Xenco Laboratories  
 PO Box 2256  
 Stafford, TX 77497  
 Ph: (281) 240-4200 Fax (281) 240-4280  
 Houston - Dallas - San Antonio - Midland  
 ACH: Routing: 26-708-4131  
 Bank Account: 12-871-1560

31392 WAB2



Kung

15

(3)

36

10-06-16

<b>Austin Harrison</b> ✓ <b>1520 Richardson Dr Apt 1216</b> <b>Richardson TX 75080-4694</b> <b>United States</b>	Folio No. : <b>13810</b> A/R Number : Group Code : Company : <b>les</b> Membership No. : <b>PC 391314526</b> Invoice No. :	Room No. : <b>325</b> Arrival : <b>10-03-16</b> ✓ Departure : <b>10-05-16</b> ✓ Conf. No. : <b>67737840</b> Rate Code : <b>IGCOR</b> Page No. : <b>1 of 1</b>
---	---	--

Date	Description	Charges	Credits
10-03-16	*Accommodation	149.00	
10-03-16	State Tax 6%	8.94	
10-03-16	City Tax 7%	10.43	
10-04-16	*Accommodation	149.00	
10-04-16	State Tax 6%	8.94	
10-04-16	City Tax 7%	10.43	
10-05-16	American Express XXXXXXXXXXXX3007		336.74

Thank you for staying with us! Qualifying points for this stay will automatically be credited to your account. Please tell us about your stay by writing a review here - [www.ihgrewardsclub.com/review](http://www.ihgrewardsclub.com/review). We look forward to welcoming you back soon.

<b>Total</b>	<b>336.74</b>	<b>336.74</b>
<b>Balance</b>	<b>0.00</b>	

**Guest Signature:** \_\_\_\_\_

I have received the goods and / or services in the amount shown heron. I agree that my liability for this bill is not waived and agree to be held personally liable in the event that the indicated person, company, or associate fails to pay for any part or the full amount of these charges. If a credit card charge, I further agree to perform the obligations set forth in the cardholder's agreement with the issuer.

Holiday Inn Express & Suites Edinburg  
3801 S Closner Blvd  
Edinburg, TX 78539  
Telephone: (956) 378-9955 Fax: (956) 513-1011



204311

Please Remit to:  
Sunbelt Industrial Services (2226)  
P.O. Box 2201  
Decatur, AL 35609-2201

# Invoice

2415 Cullen Street  
Fort Worth, Texas 76107

(4)

Rep	Date	Invoice #
LCM	10/14/2016	702840

Phone # 817-877-0866  
Fax # 817-877-0428

**Bill To**  
Half Associates, INC. (418695)  
1201 North Bowser Rd.  
Richardson, TX 75081

**Site Address**  
Hidalgo Firing Range  
902 Doolittle  
Edinburg, Texas

HOLD

Job #	P.O. No.	Terms	Due Date	Contact Name
TR16-038		Net 30	11/13/2016	Conrad Harrison

Quantity	UOM	Description	Rate	Amount
1	Lump Sum	Mobilization	1,380.00	1,380.00
3	Days	Operator & Per Diem	650.00	1,950.00
1	Lump Sum	120 Excavator	4,000.00	4,000.00
1	Lump Sum	Medical Monitoring	250.00	250.00
1	Lump Sum	POPE	200.00	200.00
2	Rolls	Poly	90.00	180.00
1	Loads	Transport to US Ecology	1,075.00	1,075.00
8	Loads	Transport to US Ecology	990.00	7,920.00
190	Tons	Disposal Hazardous Soils	225.00	42,750.00

ADD 3139Z  
WA0Z  
RB

	<b>Subtotal</b>	\$59,705.00
	<b>Sales Tax (8.25%)</b>	\$0.00
	<b>Total</b>	\$59,705.00

204122

(5)

<b>Invoice/Credit No.</b>	56069634	<b>Invoice Date</b>	October 17, 2016
<b>Terms</b>	See Below	<b>Federal Tax ID</b>	23-2919996
<b>Remit to</b>	TestAmerica Laboratories, Inc. PO BOX 204290, Dallas, TX 75320-4290		

<b>Bill to:</b>
Half Associates Inc. Attn: Accounts Payable 1201 North Bowser Road Richardson, TX 75081

<b>Ship to:</b>
Half Associates Inc. 1201 North Bowser Road Richardson, TX 75081

<b>P.O. Number</b> AVO 31392 / WA02	<b>W.O. Number</b>	<b>Contract Number</b>	<b>Work Ordered by</b> Conrad Harrison
<b>Job Description</b> See below	<b>Site Name</b>	<b>SDG Number</b>	<b>Invoice Contact</b> Conrad Harrison

Job No.	Job Description Method/Test Description	Receipt Date	Quantity	Unit Price	Amount
J64129-1	31392 6010B - Lead & Copper Moisture - Percent Moisture Deliverables - TRRP Report (%) Safe and Environmentally Responsible Waste Management (per sample)  <i>Verification samples for Hidalgo Basin excavation</i>	10/04/2016	✓ 5.00 ✓ 5.00 ✓ 1.00 ✓ 5.00	✓ 114.00 ✓ 30.00 ✓ 72.00 ✓ 1.50	✓ 570.00 ✓ 150.00 ✓ 72.00 ✓ 7.50
<i>OK to pay</i>					
<i>LIB</i>					<i>No Tax</i>

<b>Project Number</b> 56006144	<b>Client Number</b> 1424978	<b>Project Manager</b> Nicole Boyken	<b>Subtotal</b>	✓ \$799.50
<b>Latest Sample Receipt Date</b> 10/04/2016	<b>Latest Report Date</b> 10/06/2016	<b>Phone Number</b> (361) 800-5200	<b>Total</b>	\$799.50

For proper credit, please include invoice number on all remittance.

TestAmerica Corpus Christi - 1733 N. Padre Island Drive, Corpus Christi, TX 78408

This invoice falls under TestAmerica Laboratories Inc. Standard T&C's of Net 30 Days unless superseded by another valid contract vehicle in place at the time these services were rendered.